

HEX CAP SCREW SPECIFICATIONS

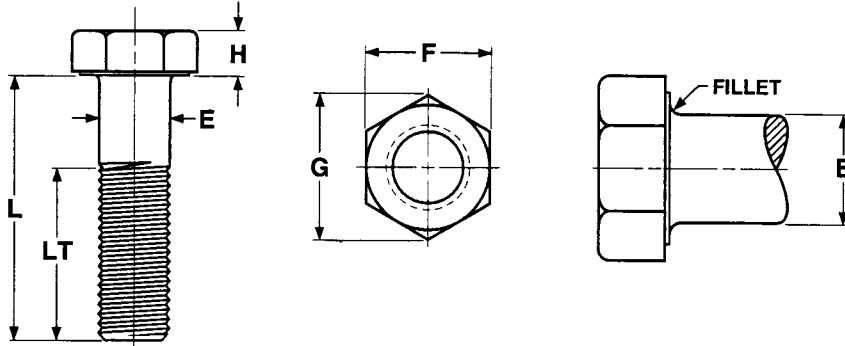

Nominal or Basic Product Dia.	E		F			G		H			R	LT		
	Body Diameter		Width Across Flats			Width Across Corners		Head Height			Radius of Fillet	Thread	Length	
	Max.	Min.	Basic	Max.	Min.	Max.	Min.	Basic	Max.	Min.		Min.	For Screw Lengths ≤ 6 in.	For Screw Lengths > 6 in.
1/4	0.2500	0.2500	0.2450	7/16	0.438	0.428	0.505	0.488	5/32	0.163	0.150	0.015	0.750	1.000
5/16	0.3125	0.3125	0.3065	1/2	0.500	0.489	0.577	0.557	13/64	0.211	0.195	0.015	0.875	1.125
3/8	0.3750	0.3750	0.3690	9/16	0.562	0.551	0.650	0.628	15/64	0.243	0.226	0.015	1.000	1.250
7/16	0.4375	0.4375	0.4305	5/8	0.625	0.612	0.722	0.698	9/32	0.291	0.272	0.015	1.125	1.375
1/2	0.5000	0.5000	0.4930	3/4	0.750	0.736	0.866	0.840	5/16	0.323	0.302	0.015	1.250	1.500
9/16	0.5625	0.5625	0.5545	13/16	0.812	0.798	0.938	0.910	23/64	0.371	0.348	0.020	1.375	1.625
5/8	0.6250	0.6250	0.6170	15/16	0.938	0.922	1.083	1.051	25/64	0.403	0.378	0.020	1.500	1.750
3/4	0.7500	0.7500	0.7410	1-1/8	1.125	1.100	1.299	1.254	15/32	0.483	0.455	0.020	1.750	2.000
7/8	0.8750	0.8750	0.8660	1-5/16	1.312	1.285	1.516	1.465	35/64	0.563	0.531	0.040	2.000	2.250
1	1.0000	1.0000	0.9900	1-1/2	1.500	1.469	1.732	1.675	39/64	0.627	0.591	0.060	2.250	2.500
1-1/8	1.1250	1.1250	1.1140	1-11/16	1.688	1.631	1.949	1.859	11/16	0.718	0.658	0.060	2.500	2.750
1-1/4	1.2500	1.2500	1.2390	1-7/8	1.875	1.812	2.165	2.066	25/32	0.813	0.749	0.060	2.750	3.000
1-3/8	1.3750	1.3750	1.3630	2-1/6	2.062	1.994	2.382	2.273	27/32	0.878	0.810	0.060	3.000	3.250
1-1/2	1.5000	1.5000	1.4880	2-1/4	2.250	2.175	2.598	2.480	15/16	0.974	0.902	0.060	3.250	3.500

ABSTRACT OF SAE J429 1985

MECHANICAL AND MATERIAL REQUIREMENTS OF GRADES 2, 5 & 8 HEX HEAD CAP SCREWS

Grade Designation	Products	Nominal Size Dia., In.	Full Size Bolts, Screws Studs, Sems		Machine Test Specimens of Bolts, Screws and Studs				Surface Hardness	Core Hardness		Grade Identification Marking L
			Proof Load (Stress) psi	Tensile Strength (Stress) Min., psi	Yield Strength (Stress) Min., psi	Tensile Strength (Stress) Min., psi	Elongation Min., %	Reduction of Area Min., %		Rockwell 30N Max.	Rockwell Min. Max.	
GRADE 2 ASTM A307 GRADES A & B	Bolts, Screws, Studs	1/4 thru 3/4	55,000	74,000	57,000	74,000	18	35	—	B80	B100	
		Over 3/4 to 1-1/2	33,000	60,000	36,000	60,000	18	35	—	B70	B100	
SAE J429 GRADE 5 ASTM A449	Bolts, Screws, Studs	1/4 thru 1	85,000	120,000	92,000	120,000	14	35	54	C25	C34	
		Over 1 to 1-1/2	74,000	105,000	81,000	105,000	14	35	50	C19	C30	
8 ASTM A354 GRADE BD	Bolts, Screws, Studs	1/4 thru 1-1/2	120,000	150,000	130,000	150,000	12	35	58.6	C33	C39	